

Table of contents

1. Purpose	1
2. System Brief.....	1
3. System Requirements.....	1
4. Safety Precautions	2
5. Brief.....	4
6. Parts name and function.....	5
7. Keyboard.....	7
8. Specification.....	15
9. The installation USB driver.....	16
10. System software	18
11. Instruction.....	18
12. How to operate the CNC router	24
13. Organic material	28
14. Appendix I: parameter for engraving tools	27
15. Appendix II	28

1. Purpose

We write this manual in order to make our customer more easily to learn and master the operation of this CNC router with Version 3.01 control system.

This manual is suitable to all users and the technicians who work on Version 3.01 CNC router.

2. System brief

Creation CNC router control system Version 3.01

3. System Requirements

Processor	Pentium III upwards、
RAM	256 M、
Video	800*600、1024*768。
Working disk space	4G
Operating system:	Windows 2000
Other	CD-ROM driver or DVD driver Free USB, PCI slot



Installation



- Checking accessories according packing list.
- Fix machine on stable concreted floor; adjust in horizontal position, by screw pad in 4 corner of machine.
- Fill water and emulsification oil in the tank (Note: emulsification oil and water by 1:4 proportions)
- Connect all the water pipe, and turn on the pump, check water pump work properly



4. Safety precautions





CAUTION

	WARNING	Any improper operation possibly results in hazard of life or equipment damage.
	CAUTION	Any improper operation possibly results in hazard of life or other objects.

	The symbol is prepared to arouse operator's highly attention. The symbols in triangles specify the cases to be attentive. The symbol in the left warns you of electric shock.
	The symbol specifies the activities to be forbidden. The symbol in the left tells you "no detachment"



WARNING

	Don't use the power source which is short of rating voltage, otherwise fire or electric shock may be resulted in.
	If the machine gives out smoke or unpleasing smell, or noise sounds etc, please do not use it. In such abnormal cases, continuing usage may result in fire or electric shock.
	Make sure the machine is grounded otherwise this may result in electric shock or mechanical function.
	Don't detach, repair or reconstruct the machine.
	CAUTION



Don't touch bits tip with your finger to prevent injury.



Machine's construction is precise, do not detach freely.

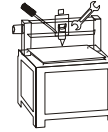

Don't use causticity liquid for cleanout machine parts and keyboard.



According to different engrave materials and enact appropriate feeding speed.



When make "Z" axis moving, please turn on spindle before operating.

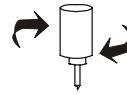

Checking cooling system before daily work.



Don't bend, pull, bundle the power cable excessively or place weight on it. Otherwise the power source may be damaged even fire or electric shock is thus incurred.

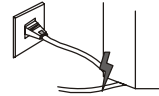

If you are not going to use the machine for a long time, please unplug the power cable from the receptacle, otherwise fire may possibly occur.



When operating the machine, do not touch cutter and spindle with your finger to prevent injury or affection of engraving.

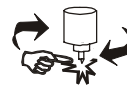

To unplug the power cable from receptacle, please hold the plug instead of the cable, strongly pulling of cable possibly results in electric shock or fire.

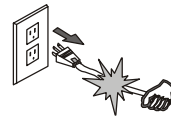

Liquid can't be leaked into machine, or drop metal units etc, regular cleaning of the machine to remove any rust or cutting debris is required and also periodic lubricant for lead screw and rail is necessary. Otherwise possibly result in fire.

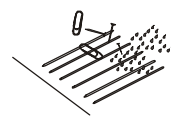

5. Brief











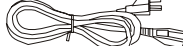

CTE-3025

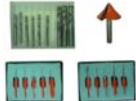
Features:

- 1、 Compact steel structure
- 2、 High precision ball screw transmission, ceramic self lubricate bush.
- 3、 3D-engraving,
- 4、 PWM micro step driver technology
- 5、 High frequency spindle, digital rotation control..
- 6、 Max transverse speed =9mt/min, feed speed =6mt/min.
- 7、 Support compatible HP/GL , G-code command, support all CAM software. : UG, Cimatron, Master,-CAM, Casmate, CAXA, Art CAM, Type 3, VectorSoft...etc.
- 8、 UCANCAM V9 2D/3D Software with USB security Dongle Supplied.

6. Part and function

6.1 Packing list:

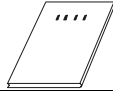
No	Item		Quantity	Icon
1	Mainframe	CTE3025	1	
2	Power cable	18AWG×3C	1	
3	USB cable		1	
4	Spindle water cooler	1kw	1	
5	blades		18	
6	Clamp		8	
7	collet		1	
8	Controller		1	
9	Open spanner	17×19mm 12×14mm	1 /size	
11	driver software		1	
12	System software		1	
13	manual		1	
14	Warranty card		1	
15	Certificate		1	

6.2 parts and function:

1、front view

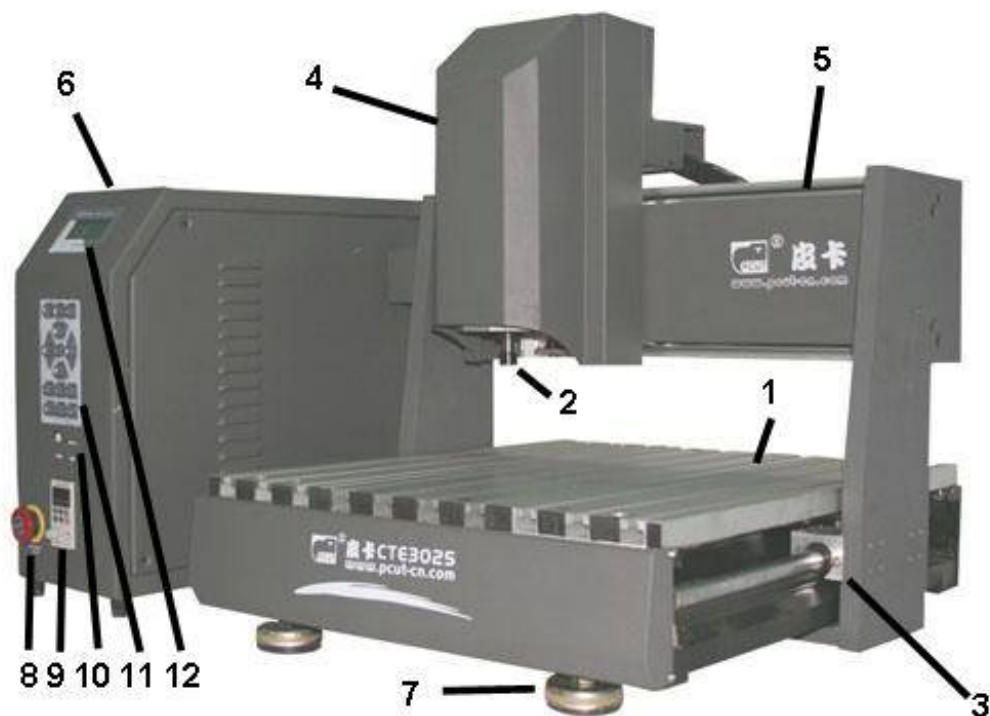

- | | |
|----------------------|--------------------------|
| 1 . Working platform | 7. Adjustable feet |
| 2. Spindle | 8. Stop Button |
| 3. Y- Axis assembly | 9. Spindle speed control |
| 4. Z - Axis assembly | 10. SD Card interface |
| 5. X - Axis assembly | 11. Keypad |
| 6. Control Unit | 12. LCD Display |

7

7.1: : Instruction

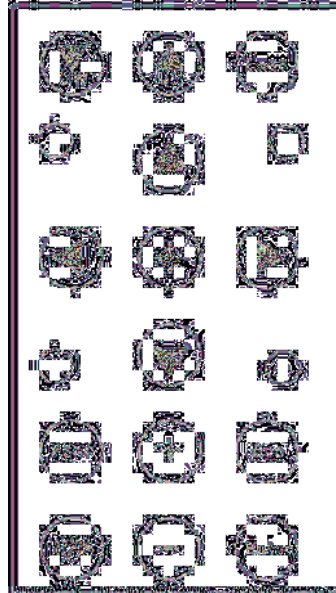

Z-



Z +

Z-axis motion control group



X-



X+

X-axis motion control group



Y+



Y-

Y-axis motion control group



Set origin / read file attribute.



Exec

Execution file



Func

Function

Origin

Go Absolute Origin

Go Job Origin

Save Job Origin,

Call Job Origin

Parameters Setting

Transverse speed,
Manual speed,
Down speed,
Feed speed

Other Function

Continue file
Machine ID,

Firmware Version,



Pause / spindle control

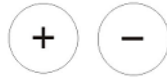

Value adjusts.



Conform.



Abort / move mode

7.2: LCD display

After power on initiation procedure, all axes must back to home position. To activated soft limit sensor.
Display will show below

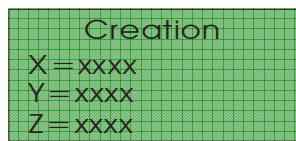





7.2.1:

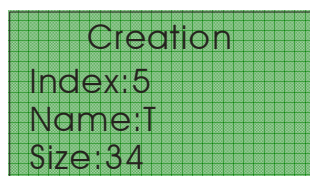

Execution



Execute file?
index: Fxx (x=file index)
name: xxxxxx (x=File name)
size: xxxK (x=File size)
Example show below:



Click  or  key to select file , click  to conform.

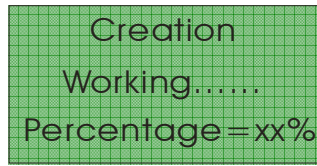

Work status.



Press  to pause, and press  to resume

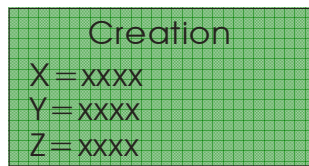

Pause status. Display will show current coordinate:





In pause status, can press  to adjust feed speed, press  to conform ,

press  key to abort.

7.2.2:  **Set origin / read file attribute.**

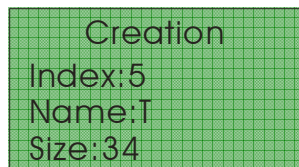
Press  key to reset X,Y,Z axe. Press  key



Press  can read file attribute.

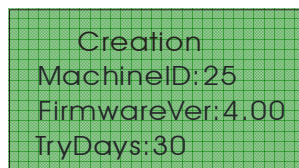

7.2.3:  **Function**

Menu:



- Origin,
- Save home,
- Call home,
- Set parameters,
- Other function

7.2.3.1 Go origins

Pressing  key will display origins setting sub menus in sequence:

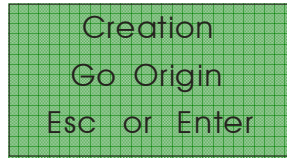
“Go origins” sub menu



Press  key conform, press  key to abort



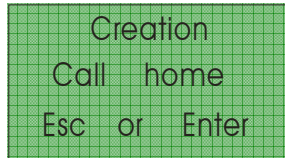

7.2.3.2 Call home

“Call home” sub menu.

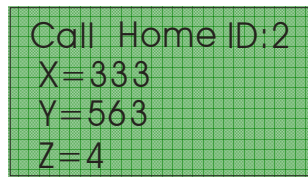

Press  key, display show below:



Combine  or  and  key to select origin ID, press  to abort.

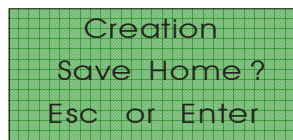

7.2.3.3 Save Home

“Save home” sub menus

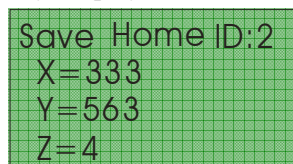

Press  key, display show below:



Combine  or  key to select origin ID, press  conform, system will save current coordinate be origin.

7.2.3.4 Parameter setting

“Parameter setting” sub menus

```

Creation
Set Params ?
Esc or Enter

```



Pressing  key will display speed setting sub menus in sequence:

“Transverse speed “sub menus

```

Creation
Fast Speed = 2000
+ Or -

```

Combine  or  key to select origin ID, press  to conform.

Press  to abort.

“Manual speed setting” sub menus

```

Creation
Hand Speed = 3000
+ Or -

```





Press  key display “transverse speed menus “show below

“Down speed setting” sub menus

```

Creation
down Speed = 2000
+ Or -

```

Combine  or  key to setting current speed, press  to conform, press  to abort.



“Feed speed setting “sub menus

```

Creation
Work Speed = 2000
+ Or -

```

Feed speed

Combine  and  to setting current speed value, press  key to conform,

press  to abort.

7.2.3.5 Others functions

“Others function” sub menu

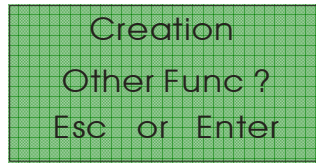

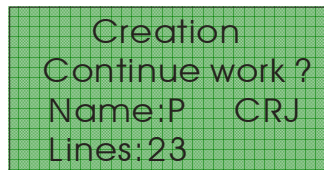

Press  key display show below

Last interrupter job menu

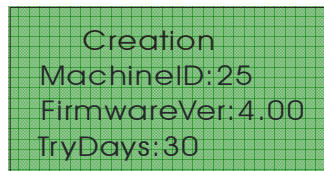

Press  will show” file attribute” menu





Press  to quit.

7.2.4: Switching move mode:

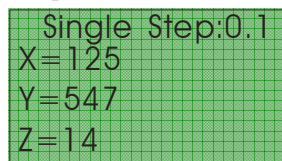
Pressing  key,
Show below single step move sub menus :



First row number is pitch value, using  and  keys to setting pitch length, move axes

with arrow keys     

7.2.5:  Pause

In working status:

```



Creation
Working.....
Percentage=xx%
    
```

Press  to pause or press again to reassume.

In service status:

```

Creation
Run Spindle?
    
```

Press  to run. Press  to stop.:

7.3: Initial sequence

1. Power on, all axes will go to absolute origin.
2. Setting job origin
3. Reset coordinate
4. Save job origin
5. Launch file
6. Conform

TIP: when system breaks down accidental, restart the system, Pressing  key to “other function” menu.

Press  , display show menu below

```

Creation
Continue work?
Name:P CRJ
Lines:23
    
```

Name: file name

line: 23 (command line interrupted).



Press key to reassume,



to abort.

```
Creation  
MachineID:25  
FirmwareVer:4.00  
TryDays:30
```

When system in working status

```
Creation  
Working.....  
Percentage = xx%
```

Only



and



key activated.

8. CTE3025 specification

model	CTE3025
Table size(mm)	500*550
X,Y,Z working area (mm)	300*250*100
Max rapid transverse (mm / min)	9000
Max feed speed (mm / 分)	6000
Resolution (mm)	0.05
Repeatability	0.05
Max feeding height (mm)	100
Max engraving height (mm)	300
Motor driver	Micro-step
Power consumption (w)	300w
Spindle	1000W water cooling/ ϕ 6、 ϕ 3.175
Rotation range	1000-24000 rpm
interface	USB/SD card
protocol	Compatible HP/GL, G-code
Operation environment	Temperature: +5°C~+35°C, relative humidity: 30%-75%
Power voltage	AC220V \pm 10% 50HZ
Net weight	100kg
Dimension W*D*H	630*580*635

9. The installation of USB driver for non SD Card models

9.1 Connect keyboard to machine, then power on.

9.2 When finished initialization, the screen will show the coordinates .connecting USB cable to machine and PC

9.3 Computer will discover new hardware.

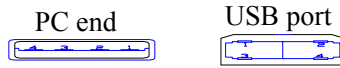

Window will POP-UP hardware wizard screen

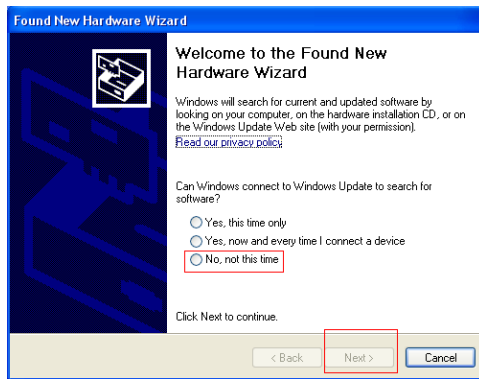

click Next >

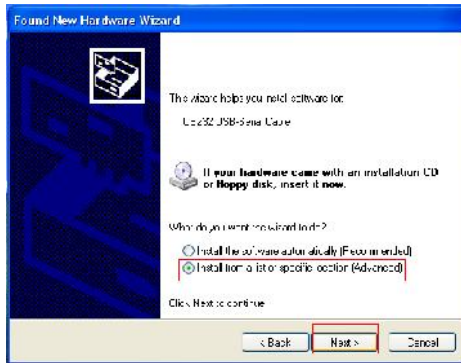

Click Next >

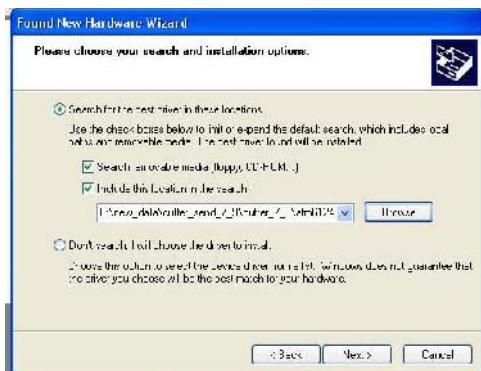

"The CD-ROM driver (C), assigns a position (C)" in front of the square to hit "√" under, then clicks on "next step" the key;



Log ,locate CD- ROM driver,



After found the document, clicks "OPEN" the key;

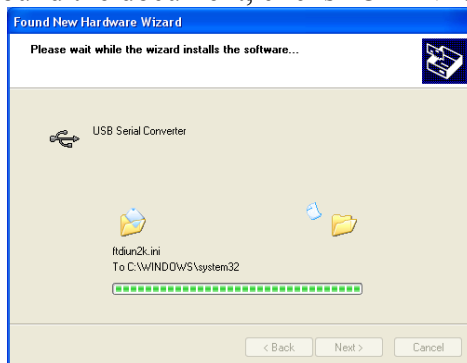

Click

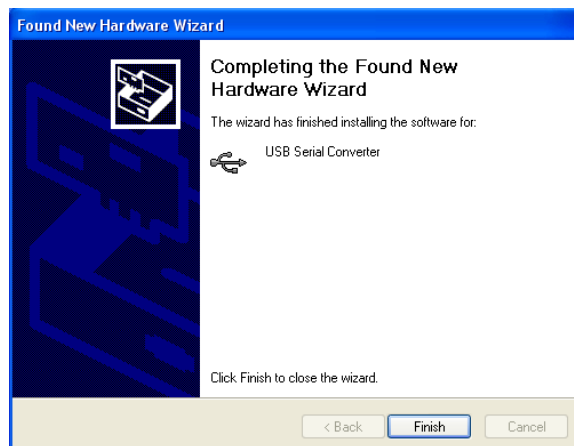

When installation finishes, the screen will shown at up appears, Click [Finish] .

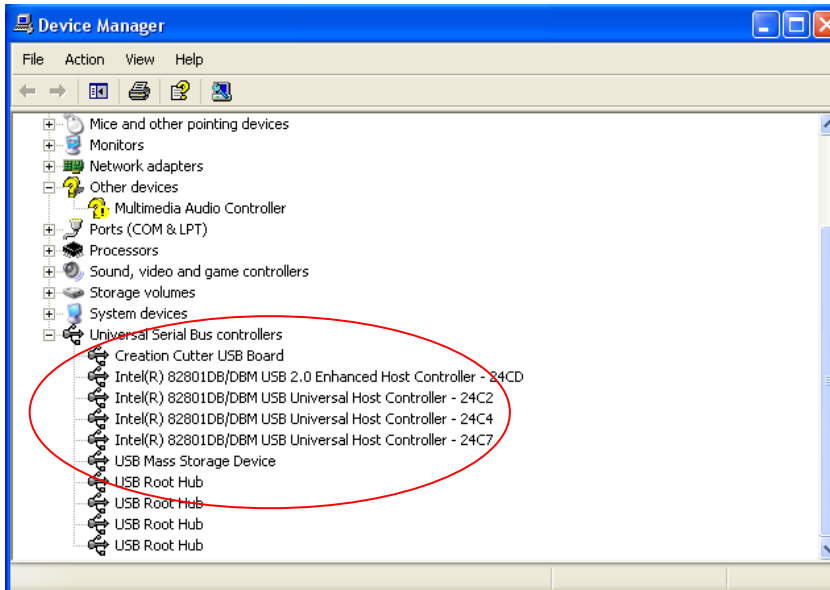

Examines the hardware to look the equipment “creation cutter USB board”

10. System software:

10.1 Brief:

10.2 Launch software

10.3 Open file with *.plt or *.nc. format

10.4 Import the file into the EngravePC program (supplied) and convert to .crj format.

10.5 Save the file in the SD card, insert SD card to machine, then use keyboard to operate the machine.

11. Instruction.

EngravePC file conversion software.

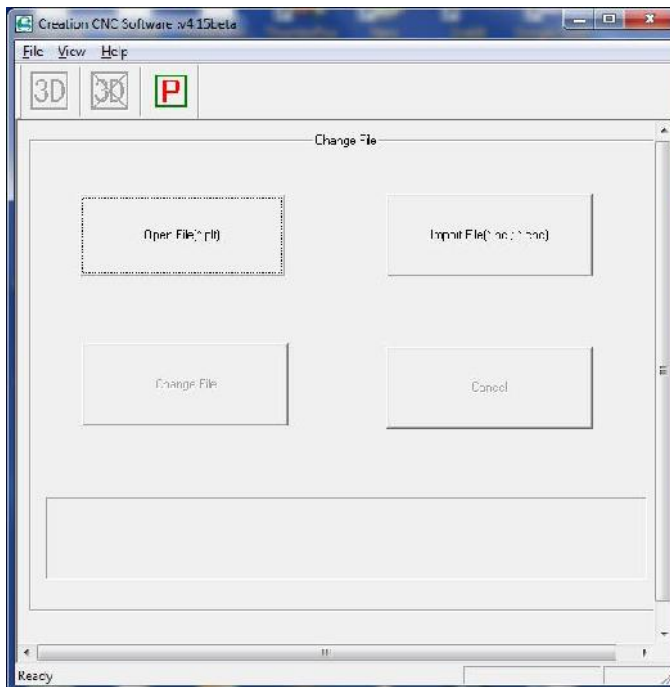

11.1 Open PLT format file

OpenFile (*.plt)

11.2 Import nc / cnc file

ImportFile (*.nc ; *.cnc)

11.3 Converting file

ChangeFile

When the system is converting the data, the screen will show like below:

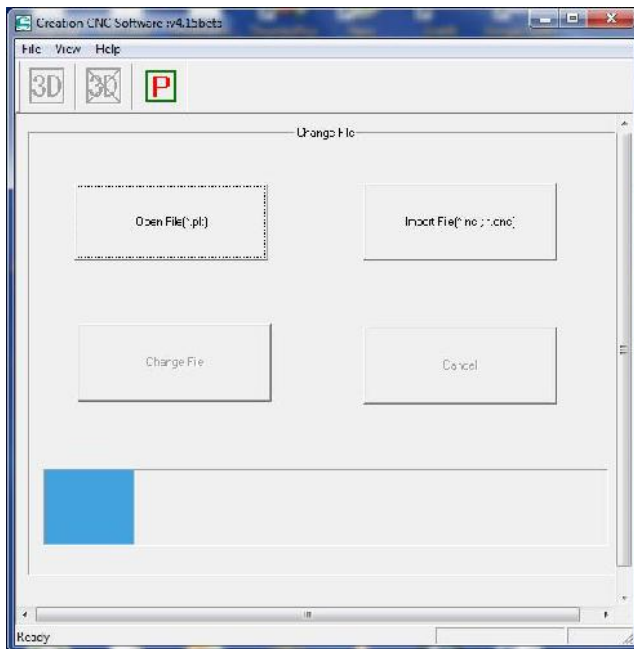

When the files have been converted, system will show you the name of the file and the path ,the name will be the same as the original file, and the suffix is “.crj”.

11.4 You can cancel the converting when it is on proceeding.



11.6 Preview of the image, please open the file before click this icon.



Open preview menu..

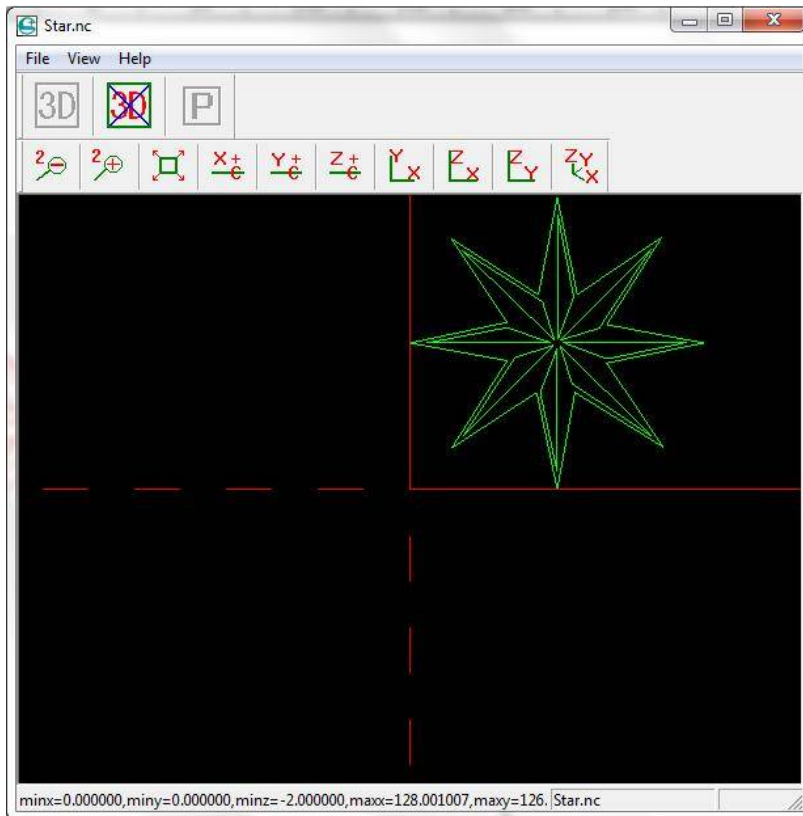

Preview tools:

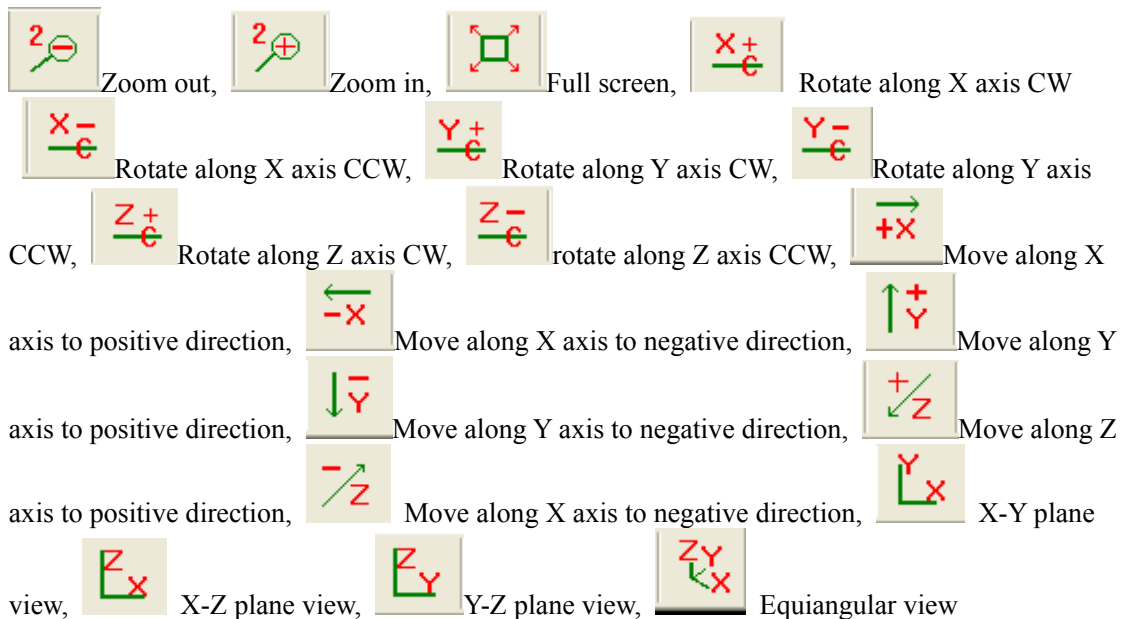

Status bar info:

minx=0.000000,miny=0.000000,minz=-2.500000,maxx=9.999000,maxy=16.665001,maxz=5.000000 bihu10_17_2.nc

Show minimum X, Y, Z coordinate and maximum X, Y, Z coordinates, and the file name.



12. How to operate the CNC router:

12.1 Save file to SD card, then insert SD card in to the slot of keyboard.

12.2 Power on machine.

12.3 How to work in ArtCut engraver software:

12.4 How to work in ArtCam software:

12.5 Save the tool path file, the processor is: xyz..nc, as blow:

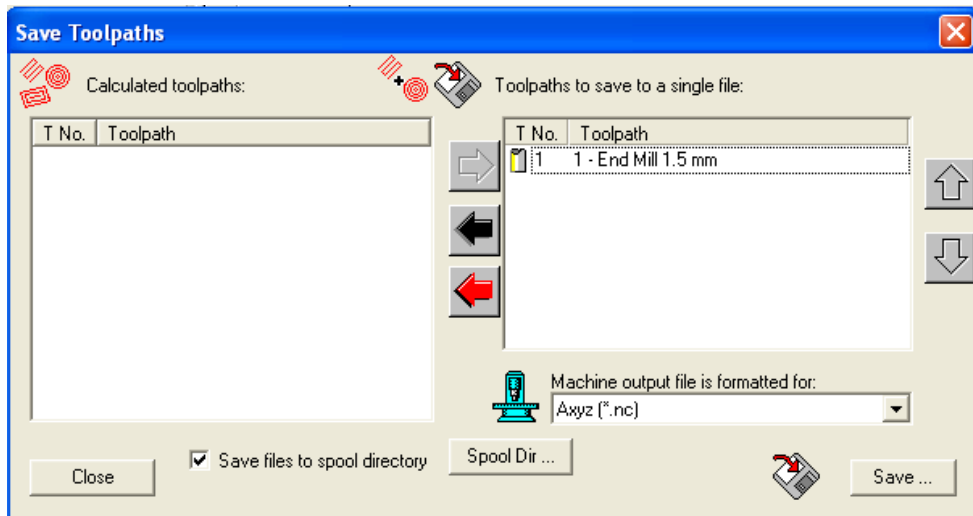

Or select CamtechCNC3MM (*.nc), as blow:

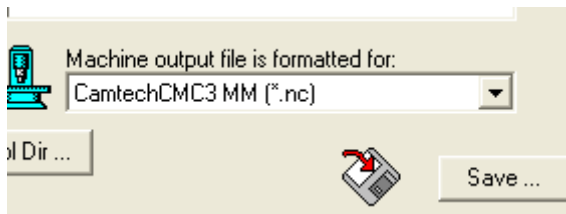

Please be careful of the back processor, it will contain some irecognizable code.

12.6 How to use Mastercam software to make file;

After finish the toolpath, when you save the path, please select “mpfan.pst” processor, if software do not tolerant this processor, please click “change post” button to change the processor like below:

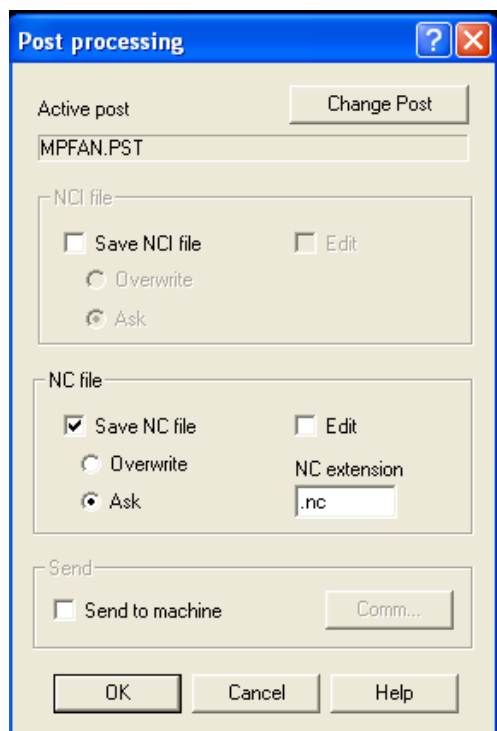

12.7 Compatible HP/GL protocol:

IN;	program initialization
SPx;	blade start(x= blade no)
SP0;	program over
PU	up blade,
PD	down blade
PA	absolute coordinate system.

12.8. G-Code command

Back process: MPFAN.PST

% : Starting symbol

G00: Linear rapid motion

G01: Linear interpolation motion

G02: Clockwise interpolation/ helical interpolation

G03: Counter Clockwise interpolation/ helical interpolation

G17、 G18、 G19: Plane selection

G28: Return to reference point

G43: Tool length compensation+

G54, G55, G56, G57, G58, G59: Select work coordinate system

G73: High-speed peck drill canned cycle

G80: Canned cycle cancel

G81: Drill canned cycle

G83: Normal peck drill canned cycle

G90: Absolute

G91: Incremental

G98: Initial point return

G99: R plane return

F: Feed speed

S: Spindle speed

T: Tool choose

M00: Stop program

M03: Spindle forward

M05: Spindle stop

M06: Tool change

M07: Air pump on

M08: Oil pump on

M09: Air off and oil off

M30, M02: Program end

System Default

G90: Absolute

G54: Select work coordinate system 1

G49: Tool length compensation cancels

G40: Tool compensation cancels

G21: Select metric

G17: XY plane selection

12.9 .Routine service

12.9.1 The main board has limit switch function, if the limit switch no activated, please restart the machine.

12.9.2If the software are out of validate, please consult our local agent or distributor.

Note: adjust z-axis depth so when machine in pause status Z- axis coordinate is absolute value, no relate with old.

12.10.You should choose FAT 32 file system to format SD card.

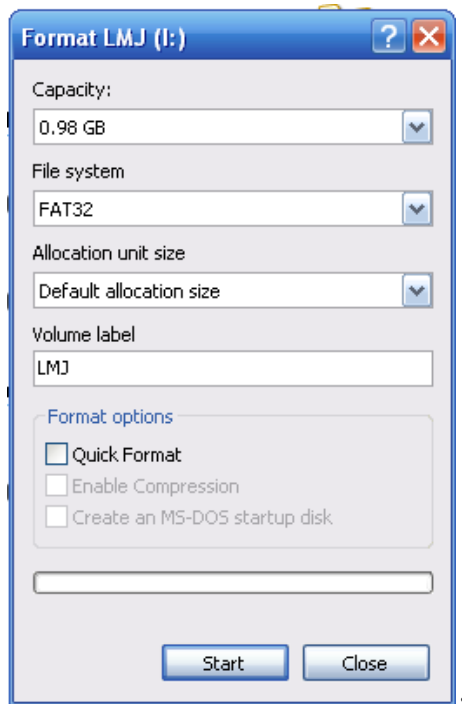

Searching the 64 files which are in CRJ format, please making sure to copy the CRJ format files to the SD card directly;

Note: do not store file in folder.

13.Organic material

Mode	Tungsten alloy bits	Spindle speed (rpm)	Feed speed (m/min.)	Feed depth	Remark
Marble	20°~30°/0.1~0.3	20000~40000	0.3 all low speed	0.2~0.4mm	
	Above 20°~30°/0.3	20000~40000	0.3 all low speed	0.3~0.4mm	
	Above 40°	20000~40000	0.6	0.3~0.5mm	
Glass	20°~30°/0.1~0.3	20000~40000	0.3	0.1~0.2mm	
	Above 20°~30°/0.3	20000~40000 40000	0.3 0.6~2.4	0.1~0.4mm 0.1mm	
	Above 40°/above 30°	20000~40000 40000	0.3 0.6~2.4	0.1~0.4mm 0.1mm	

Various wood:

Mode	Tungsten alloy bits	Spindle speed (rpm)	Feed speed (m/min.)	Feed depth	Remark
Engrave	20°~30°/0.1~0.3	20000~40000	0.8~2.4	0.5~2mm	
	Above 20°~30°/0.3	20000~40000	1.2~2.4	1~3mm	
Cutting	φ0.8~φ1.3	10000~20000	0.3 all low speed	1~3mm	
	Above φ0.8	10000~20000	0.3 all low speed	3~8mm	

14. Appendix I: parameter for engraving tools

Engrave different material, using appropriate tools and parameter.

Material are: ABS board, acrylic, PVC board, metal, copper, aluminum, wood, composite material, inorganic material etc.

Application: modeling, die tool, rapid prototyping, stamp, furniture etc.

15. Appendix II: maintenance

Maintenance is an important way to prolong the engraver's life and to improve production efficiency. There are two ways for maintenance, daily maintenance and periodical maintenance; the details as below:

1、Daily maintenance needs cleaning up towards working plane and equipment after work is over everyday, especially for generous movement parts (such as smooth shaft, beeline bearing) should be cleaned up timely. Periodical maintenance should be done every three months, periodic maintenance aiming at cleaning up equipment, insures lubricated and environment conditions towards engraver movement, meantime should add "No.2 grease" or "No.2 machine oil" to rail periodically every six months.

2、engraver major engages in process business, during machining will produce more flour and dust. So we should pay attention to cleanout, lubricate towards rail, lead screw etc., rust proof and waterproof should be done towards these components. Timely sweep dust and adding oil to transmission parts; operator should clean, adding oil, and strictly prohibit pulling out plugs with electric.

3、For daily maintenance, clean key part towards lead screw, rail, and optical coupling everyday, to prevent debris buildup on lead screw, rail, and avoid dust, bits stick to optical coupling, if this occur will influence optical coupling's sensitive degree as well as error degree.

4、lead screw, rail should be cleared and greased in time. Commonly the rail take machine oil for cleanout; for lead screw should use No.2 machine oil for cleanout, after cleanout should adding No.2 grease in order to prolong precision and longevity of lead screw as well as rail, we hereby suggest that lead screw should be cleaned everyday, rail should be cleaned every week, and adding oil every month.

5

Good maintenance can prolong machine's longevity.